

WDCL Damaged-Control-Line Replacement Safety Valve System

Restores safety-valve functionality in wells with safety-valve control-line problems without a major workover or kill fluids

Applications

- Retrofit wells with safety-valve control-line problems
- Retrofit wells without prior safety-valve installations

Features and Benefits

- Restores safety-valve functionality in wells with safety-valve control-line problems without a major workover or kill fluids
- Installs via wireline with minimal personnel and footprint
- Maximizes flow area, which reduces the pressure loss through the system, prevents choked flow, and minimizes production losses
- Uses field-proven, metal-to-metal, through-the-flapper equalizing technology for durability and reliability
- Negates the need to remove the wellhead or move flowlines through use of the Ren Gate™ wellhead-penetration conversion kit
- Reduces installation time and hanger-customization time by adjusting the overall length of the control-line hanger on location
- Conforms to API standards for both valve and wellhead equipment

Tool Description

The Weatherford WDCL damaged-control-line replacement safety valve system restores safety-valve functionality in wells with safety-valve control-line problems, including plugged-off, damaged, or leaking control lines, leaking piston seals, damaged flapper valve, or damaged flow tube. Installed via wireline, the system is an economic alternative to safety-valve replacement operations. The valve can be modified to include a self-equalizing, through-the-valve flapper (Weatherford model WDCL-E) and can be modified to fit non-Weatherford lock profiles. The system includes a wireline-retrievable subsurface safety valve, the Ren Gate™ wellhead-penetration conversion kit, a control-line hanger, and a control-line stinger.

The WDCL is run and retrieved on wireline. The tool exceeds API 14A specifications and includes a wireline safety valve, a hydraulic communication pod, and a wireline lock. The valve-and-lock assembly is installed in an existing tubing-mounted safety valve or safety-valve landing nipple with control-line failure. The wireline lock is interchangeable to accommodate most common safety-valve landing nipple profiles. The valve is available in fail-safe setting depths to 2,000 ft (610 m). The pod provides the wet-mate connection between the control-line stinger and hydraulic communication to the surface.



The WDCL damaged-control-line replacement safety valve system is an economic alternative to a major safety valve replacement operation.



WDCL Damaged-Control-Line Replacement Safety Valve System

Tool Description (Continued)

The Ren Gate wellhead-penetration conversion kit provides hydraulic communication through the wellhead to the downhole safety valve. The kit enables a wellhead retrofit without removing the wellhead or flowlines and is adaptable to most wellheads with compromising wellhead integrity. The kit also provides the necessary two barriers between wellbore fluids.

The RQXC control-line hanger (CLH) provides the hydraulic connection from the wellhead to the safety valve. The tool is run and retrieved on slickline and is available in type-H locking-dog version and a premium wireline locking-groove version. If space-out is uncertain, the CLH is available with a length adjustment feature that can be adjusted on location. The control line is securely attached and sealed to the CLH by a unique double-bend connector.

The control-line stinger connects the CLH and the WDCL safety valve. The stinger holds pressure in both directions until properly installed in the safety valve, which prevents well flow through the control-line run in a live well. The stinger includes a control-line connector, a centralizer, and a wet-mate connection. The wet-mate connector is available in 1- and 1-1/2-in. OD sizes and requires setdown weight to connect to the safety valve and overpull tension to release, which provides an accurate indicator that the stinger is correctly installed.



The control-line hanger (CLH) provides the hydraulic connection from the wellhead to the safety valve.

Specifications

Surface Equipment (Wellhead and Control-Line Hanger)

API wellhead size	3 1/16 in. (78 mm)	4 1/16 in. (103 mm)	5 1/8 in. (130.18 mm)	7 1/16 in. (179.37 mm)
Nominal H-type hanger size	3 in. (76.2 mm)	4 in. (101.6 mm)	5 in. (127 mm)	7 in. (177.8 mm)
Working pressure	Wellhead dependent			
Working temperature	-40 to 300°F (-40 to 149°C)			
Control-line hanger	H-type or premium wireline locking-groove profile			

WDCL Damaged-Control-Line Replacement Safety Valve System

Specifications (Continued)

Downhole Equipment (Safety Valve)

Size	3 1/2 × 2.813 in. (88.90 × 71.45 mm)	4 1/2 × 3.813 in. (114.30 × 96.85 mm)	5 1/2 × 4.562 in. (139.70 × 115.90 mm)	7 × 5.962 in. (177.80 × 151.43 mm)
Nipple profile	2.813 in. (71.45 mm)	3.813 in. (96.85 mm)	4.562 in. (115.90 mm)	5.962 in. (151.43 mm)
Working pressure	5,000 to 10,000 psi (34,474 to 68,948 kPa)			
Working temperature	30 to 300°F (-1 to 149°C)			
Fully open operating pressure	2,000 psi (13,790 kPa)			
Fully closed operating pressure	1,000 psi (6,895 kPa)			
Fail-safe setting depth	1,000 to 2,000 ft (305 to 610 m)			

Safe-Set System Measurement

Size	2-7/8 in. (73.0 mm)	3-1/2 in. (89.9 mm)	4-1/2 in. (114.3mm)	5-1/2 in. (139.7mm)	7 in. (177.8mm)
Maximum tubing weight	8.6 lb (3.9 kg)	12.7 lb (5.8 kg)	18.8 lb (8.5 kg)	29 lb (13.2 kg)	32 lb (14.5 kg)
Minimum tubing weight	6.4 lb (2.9 kg)	9.2 lb (4.2 kg)	12.6 lb (5.7 kg)	17 lb (7.7 kg)	17 lb (7.7 kg)
Minimum flowing ID	1.180 in. (29.97 mm)	1.433 in. (36.40 mm)	1.630 in. (41.40 mm)	2.465 in. (62.61 mm)	3.648 in. (62.61 mm)
Overall length	60 in (1,524 mm)				
Test pressure	10,000 psi (68.9MPa)				

Materials

Dynamic seal actual system	Rod piston Viton® elastomeric T-seal and Teflon® bearing backup rings filled with molybdenum verified to a 10,000-psi (68,948-kPa) gas differential pressure at 300°F (149°C)
Flapper soft material	Viton seal
Lock and most safety-valve components	13% minimum chrome; 80,000-psi (551,581-kPa) minimum yield; heat treated
Piston, rod, flapper, and seat	Heat-treated INCOLOY® alloy 925
Power spring, flapper pin, and torsion spring	Heat-treated MP35N alloy
Design specification	API 14A
Manufacturing specification	API Q1 and API 14A
Service class	3S2

Viton, Teflon, and INCOLOY are registered trademarks of their respective owners.



WDCL Damaged-Control-Line Replacement Safety Valve System

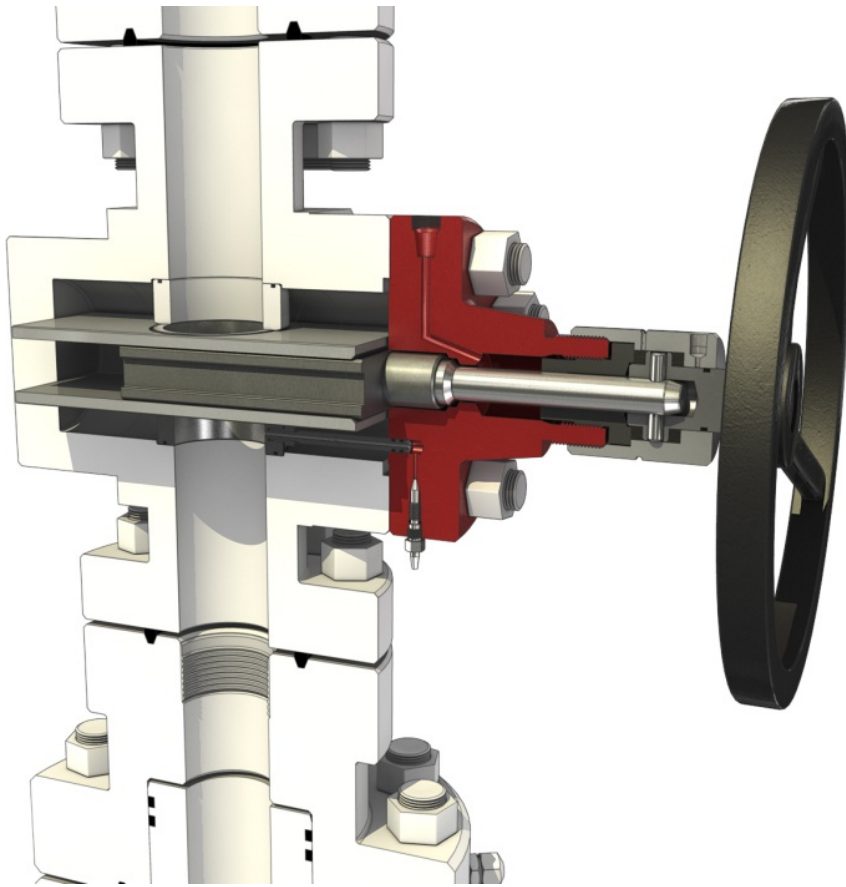

The Ren Gate wellhead-penetration conversion kit provides hydraulic communication through the wellhead to the downhole safety valve.



Optional wellhead spool.

The control-line stinger connects the CLH and the WDCL safety valve. The stinger holds pressure in both directions until properly installed in the safety valve, which prevents well flow through the control-line run in a live well.

