



Top-Drive Cementing Head (TDH)

Weatherford's top-drive cementing head (TDH) allows release of setting balls and drillpipe darts without breaking the connection in the running string.

The TDH is pre-loaded with the setting ball, drillpipe dart(s), or full-length wiper plugs (FLWPs) and can be racked in the derrick for easy access. The well can be circulated through the TDH via a top drive or cement unit with the ball and dart(s) loaded. When circulating through the side bore and/or bypassing dart(s), the maximum pump rate is 15 bbl/min. When pumping through the main bore, after plugs have been released and bypass valves are closed, the maximum allowable rate is 30 bbl/min. The ball and dart(s) can be released by the clearly identified wheels on the TDH.

Applications

- Running any liner, with or without topdrive
- Launching darts and balls related to Sub-Surface Release™ cementing plugs

Features, Advantages and Benefits

- High tensile, torque, and pressure ratings enable the TDH to withstand conditions that other heads cannot.
- The TDH allows circulation through the top drive and/or cement line, even when fully loaded, simplifying operations and saving rig time while the head is being used.
- The integral swivel facilitates rotation of the drillstring during cementing operations, resulting in a better cement bond.

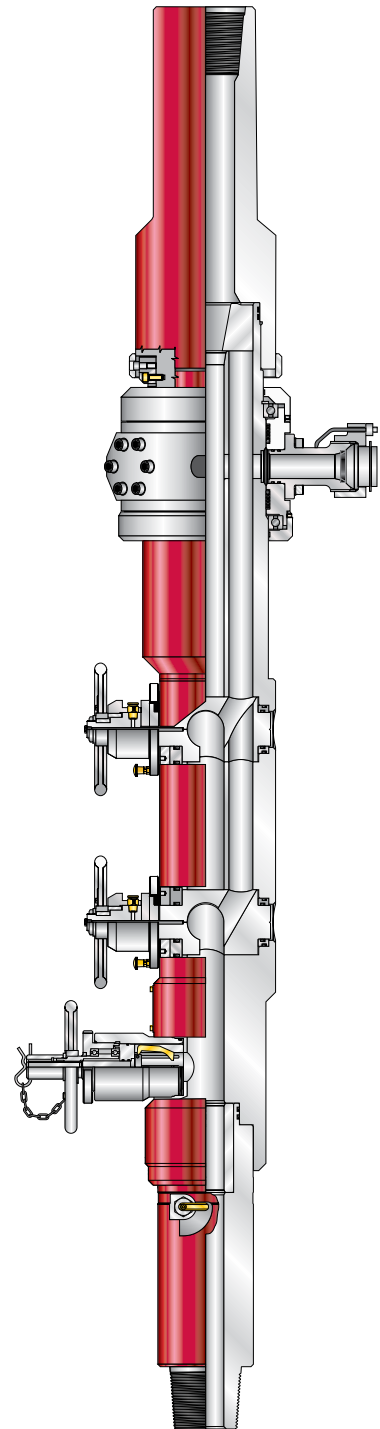



Top-Drive Cementing Head (TDH)

Specifications

Part number	01213997	
Connections (in.)	6-5/8 API full hole box × pin	
Maximum torque (lbf-ft/N•m)	80,000 108,466	
Minimum operating temperature (°F/°C)	-4° -20°	
Main bore ID (in./mm)	2.961 75.209	
Bypass channel ID (in./mm)	1.938 49.225	
Dropping ball size OD (in./mm)	1.250 to 2.250 31.750 to 57.150	
First dart chamber length (in./mm)	25 635	
Second dart chamber length (in./mm)	40 1,016	
Design Capacity	At 2.25 Safety Factor	At 1.5 Safety Factor^a
Maximum rotating speed (rpm)	40	20
Design load ^b (lb/tonne)	1,070,000 485	1,675,000 759
Working pressure (psi/MPa)	7,500 51.7	5,000 34.4
Tension only (lb/tonne)	1,210,000 549	1,815,000 823
Pressure only (psi/MPa)	10,000 68.9	
Maximum pump rates (bbl/min)	15 ^c	
	30 ^d	

^a DNV certificate is not applicable for ratings at 1.5 safety factor.

^b Design load reduced by dynamic load is equal to safe working load.

^c Through side bore or with bypass open.

^d Through top drive with bypass closed.

Maximum pump rates apply to cement head only. Other system limitations may require rate reduction, such as formation strength and pore pressure, or equipment, such as liner top packers, wiper plugs, landing collars, float equipment, etc., and must be assessed for each operation before pumping begins. Contact an authorized Weatherford representative for details.

Top-Drive Cementing Head (TDH)

